



VALERT BORDER

Protecting International Border Applications

The **V-ALERT BORDER** system provides an integrated intrusion detection solution, protecting the BORDER perimeter fence or wall as well as strategic equipment or facilities in the border area.

The versatility of the V-Alert technology enables the use of the sensor on many different types of Fences and Walls as well as on strategic assets and equipment and high security areas typically found in border crossings and International Borders.

The V-Alert sensor, a robust outdoor sensor, will provide a pin-point alarm indication along the border fence directing the Security Forces to the exact location of the intrusion.

The V-Alert Alarm indications can easily be integrated with other detection systems such as CCTV camera's which can be used to verify the alarm at the point of the intrusion.

The V-Alert Sensors provide a highly reliable alarm indication with negligible false alarm rates.

- Install on Border Fences and Border Walls.
- Detects attempts to climb or cut the Border Fence.
- Detects attempts to break through Border Wall.
- Protect Border Crossing Installations, Customs Houses and Free Trade zones adjacent to the border.
- Install on electronic equipment or any high value or classified military equipment in the border area.
- Receive a pin-point alarm indication from the border fence or strategic asset being protected.
- Install directly on specific solid structures that have been targeted for theft or damage and adjust the sensitivity to meet the security requirements of the application.
- Install on the perimeter fence surrounding the border terminals in addition to installing on the border fence.
- Each sensor has a unique ID providing fast, accurate and pin-point alarm indications.
- The sensitivity of each sensor can be adjusted according to the element on which it is installed.
- Separate sensor sensitivity adjustment and detection possible on both X and Y axes.
- Sensor designed for long-term use in extreme outdoor and weather conditions.





System Features

The **V-ALERT** INDOOR OUTDOOR DETECTION SYSTEM is an advanced intrusion detection system used in a wide variety of integrated INDOOR-OUTDOOR security applications.

The **V-ALERT** sensor is an electronic sensor with no moving parts that has been designed to detect changes in movement or vibrations caused by attempts to cut, break or remove elements in the protected site.

EACH **V-ALERT** sensor will provide an independent alarm indication from the element on which it is installed.

ONE integrated system protects all the elements in the protected site with one continuous line of V-Alert Sensors. There is no need to install other detection systems on site.

The status of each individual electronic sensor is monitored electronically and analyzed by the Zone Processor Unit. The system detects changes in the status of individual sensors providing an accurate and reliable alarm detection capability.



System Installation & Integration

- GM's V-Alert Settings Manager Application is used to program and set-up the system. The sensitivity of each individual V-Alert sensor can be adjusted.
- Alarm indications from the zone processor unit are integrated with Alarm Panels, GSM Dialers or any other available communication system or network
- Dry-contact relay outputs enable integration with other communication equipment.

Specifications

V-Alert System

2 lines of up to 50 sensors each line connected to one V-Alert Processor Card

Integration

V-Alert Relay Card with 10 Relay Outputs

Temperature

Operating temperature -40°C to +70°C

Humidity

20% - 95% condensing

Enclosure and Cable

Weather proof epoxy enclosure
Outdoor Cable – UV resistant

Input Voltage

12-30V DC

The V-Alert Sensor technology is continually being upgraded and updated. GM reserves the right to make changes to the technology and specifications of the system in order to equal or improve the system's performance.

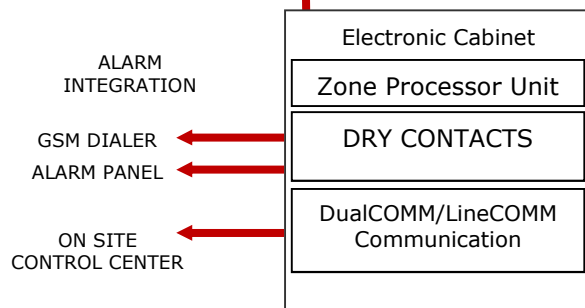

APPLICATIONS

- Border Perimeter Fences & Walls
- Border Terminals
- Border Customs Trade Areas
- Strategic Assets in Border Area
- Military Bases in the Border Area
- Military Equipment in the Border Area

